



Tanco Autowrap 580
Spare parts list



1080-A 2005
PARTS LIST
WD66-1080-M0304



SPARE PARTS LIST

We recommend that when you need spare parts, you should use only original parts.

When ordering spare Parts use the following:

- Drawings are marked with a position number.
- On the accompanying table you will find the position number, its equivalent part number and description. The entire part number and description must always be relayed on ordering.
- **IMPORTANT!**
When ordering always give the serial number on the wrapping machine and specify the Model of Machine.
- We ask that you fax your parts order to your Tanco dealer, to ensure quick delivery



TABLE OF CONTENTS

	<u>Page:</u>
1. Hydraulics	
1. Hydraulic Components	
1.1.1 Hydraulic Components Exploded View	4
1.1.2 Parts List	5
1.2 Valve and Cover Plate Exploded View and Parts List	6
2. Main Assembly	
2.1.1 Main Assembly Exploded View	8
2.1.2. Part List	9,10
2.2.1 Constant Indexing Drive Exploded View	11
2.2.2 Parts List	12
2.3 Table Locking Assembly and Parts List	13
2.4.1 Bale Belt Roller Mounting Brackets Assembly exploded View	14
2.4.2 Part List	15
2.5.1. Turntable Chain Drive Assembly Exploded View	16
2.5.2. Parts List	17
3. Lift Arm Assembly	
3.1. Exploded View	18
3.2. Part List	19
4. Cut and Start Assembly	
4.1. Exploded View	20
4.2. List	21
5. Bale Ramp	
5.1. Hydraulic Bale Ramp Exploded View and Parts List	22
6. Lighting	
6.1. Exploded View and Parts List	23
7. Film Dispenser	
7.1.1. Dispenser Mast Assembly Exploded View	24
7.1.2 Parts List	25
7.2.1 Dispenser Insert Assembly Exploded View	26
7.2.2. Parts List	27
8. Controller	
8.1 Sensors and Mounting Brackets Exploded View and Parts List	28
8.2 Controller Exploded View and Parts List	29
8.3. Junction Box Parts List	30

1.1.1 Hydraulic Components 1080A

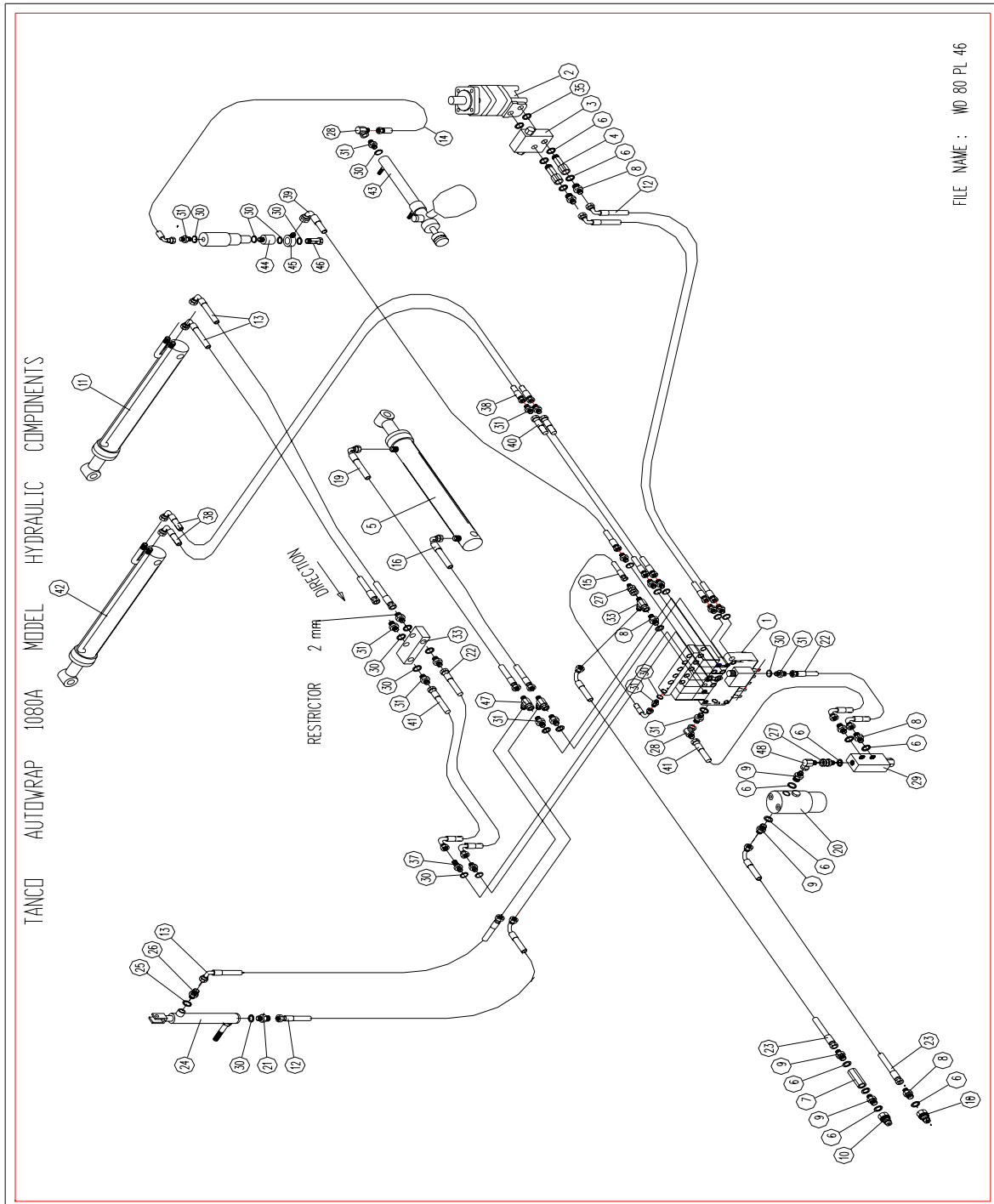



1.1.2 1080A HYDRAULIC COMPONENTS

ITEM No.	DESCRIPTION	QTY	PART No.
1.	5 Bank Spool Valve (Walvoil)	1	Z01-03-1070
2.	Hydraulic Motor	1	Z01-02-RF200
2A.	Seal Kit for above Hydraulic Motor	1	Z01-RF200
3.	Cross line Relief Valve	1	Z01-03-004
3A.	Seal Kit for above Cross Line Relief Valve	1	Z01-03-004-RF
4.	½" BSP Bottom Banjo Bolt	2	Z01-03-002B
5.	Hydraulic Ram (Tipping Frame)	1	Z01-01-AR687
5A.	Seal Kit for above ram	1	Z01-Z01
6.	½" Dowty Washer	12	Z01-04-03
7.	½" Non Return Valve	1	Z01-03-017
8.	½" x 3/8" Adaptor	4	Z01-06-06-08
9.	½" x ½" Adaptor	8	Z01-06-08-08
10.	½" Male Q/R Coupling	2	Z01-15-081
11.	Hydraulic Ram (Lift Arm)	1	Z01-01-AW1070
11A.	Seal Kit for above ram	1	Z01-Y01
12.	108" St./ 90 3/8" D/W Hose	2	Z38-R2-108-S9
13.	72" St. / 90 3/8" D/W Hose	3	Z38-R2-72-S9
14.	84" St. / 90 3/8" D/W Hose	1	Z38-R2-84-S9
15.	9" St. / 90 3/8" D/W Hose	1	Z38-R2-9-S9
16.	36" St. / 90 3/8" D/W Hose	1	Z38-R2-36-S9
17.	60" St. / 90 3/8" D/W Hose	1	Z38-R2-60-S9
19.	48" St. / 90 3/8" D/W Hose	1	Z38-R2-48-S9
20.	Filter	1	Z01-24-08
20A.	Filter Element	1	Z01-24-08E
21.	3/8" Adaptor with 2mm Restrictor	1	Z01-03-40
22.	12" St. / 90 3/8" D/W Hose	1	Z38-R2-12-S9
23.	108" St. / 90 ½" D/W Hose	2	Z12-R2-108-S9
24.	Hydraulic Ram (Pull Down)	1	Z01-01-AW25
24A.	Seal Kit for above Ram	1	Z01-AW25
25.	1/4" Dowty Washer	1	Z01-04-01
26.	¼" x 3/8" Adaptor	1	Z01-06-04-06
27.	3/8" Male x ½" Female Adaptor	1	Z01-05-06-08
28.	3/8" Male/Female 90 Elbow	2	Z01-14-015
29.	Inline Flow Divider	1	Z01-03-10-A6
30.	3/8" Dowty Washer	18	Z01-04-02
31.	3/8" x 3/8" Adaptor	16	Z01-06-06-06
32.	3/8" Male/Male/Female "T" Piece	2	Z01-12-002
33.	Over Centre Valve	1	Z01-03-10-A8
35.	Copper Washer	2	Z01-04-15
39.	96" St. / 90 3/8" D/W Hose	1	Z38-R2-96-S9
40.	48" St./St. Hose 3/8" DW Hose	2	Z38-R2-48-SS
41.	14" St. / 90 3/8" D/W Hose	2	Z38-R2-14-S9
42.	Hydraulic Ram (Squeeze Arm)	1	Z38-R2-14-S9
42A.	Seal Kit for above Hyd. Ram	1	Z01-Y01
43.	Hydraulic Ram (Cut & Start)	1	Z01-01-AWH9
43A.	Seal Kit for above Ram	1	Z01-AWH
43B.	Accumulator fitted to above Ram	1	Z01-01-AWV
44.	Rotary Coupling	1	Z01-02-AWR
45.	3/8" Banjo Coupling	1	Z01-19-062
46.	Single top Banjo Bolt	1	Z01-20-062
47.	84" St / 90 3/8" D/W Hose	1	Z38-R2-84-S9
48.	½" Male/Female 90 Elbow	1	Z01-14-016

1.2 1080A VALVE/JUNCTION BOX/FILTER COVER PLATE ASSEMBLY

ITEM No.	DESCRIPTION	QTY	PART No.
1.	Valve Cover Plate Assembly	1	WD67-VCP
2.	Junction Box Mounting Plate	1	WD67-JBM
3.	4 Bank Solenoid Valve	1	Z01-03-A550
4.	Flow Divider	1	Z01-03-10-A6
5.	Spacer	3	WD67-100
6.	8mm Mud flap Washer	2	Z11-02-081
7.	M6 Locknut	2	Z32-06
8.	Oil Filter	1	Z01-24-08
8A.	Oil Filter Element	1	Z01-24-08E
9.	M8 x 25 Hex Set	2	Z26-040S
10	8mm Spring Washer	2	Z12-02-08
11	M8 Locknut	3	Z23-08
12.	M6 x 45 Socket Cap Screw	2	Z13-020-50
13.	Over-Centre Valve	1	Z01-03-10-A8
14.	Junction Box	1	D606R-JBA
15.	M8 x 100 Hex Set	3	Z26-057S
16.	M5 x 20 Hex Set	2	Z26-017S
17.	M4 Locknut	4	Z23-04
18.	M10 x 20 Hex Set	3	Z26-060S
19.	10mm Spring Washer	3	Z12-02-10
20.	M10 Hex Nut	2	Z18-10
21.	M5 Locknut	2	Z23-05

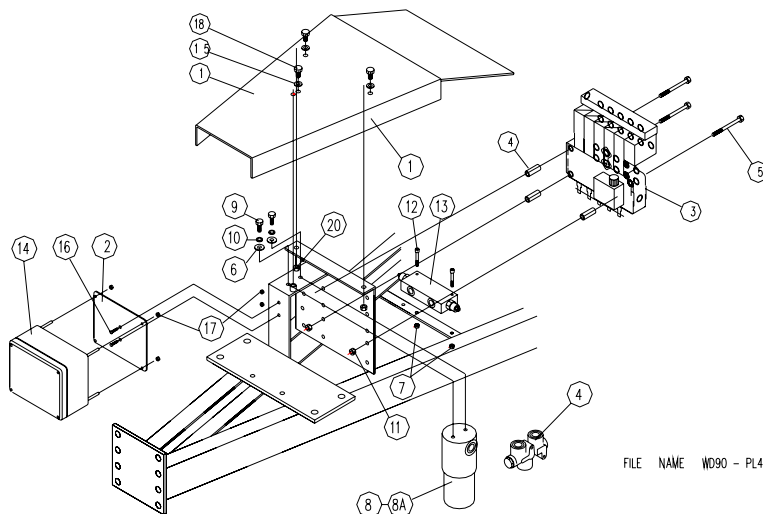

FILE NAME W090 - PL41



Tanco Autowrap 580
Spare parts list



2.1.1 Main Assembly

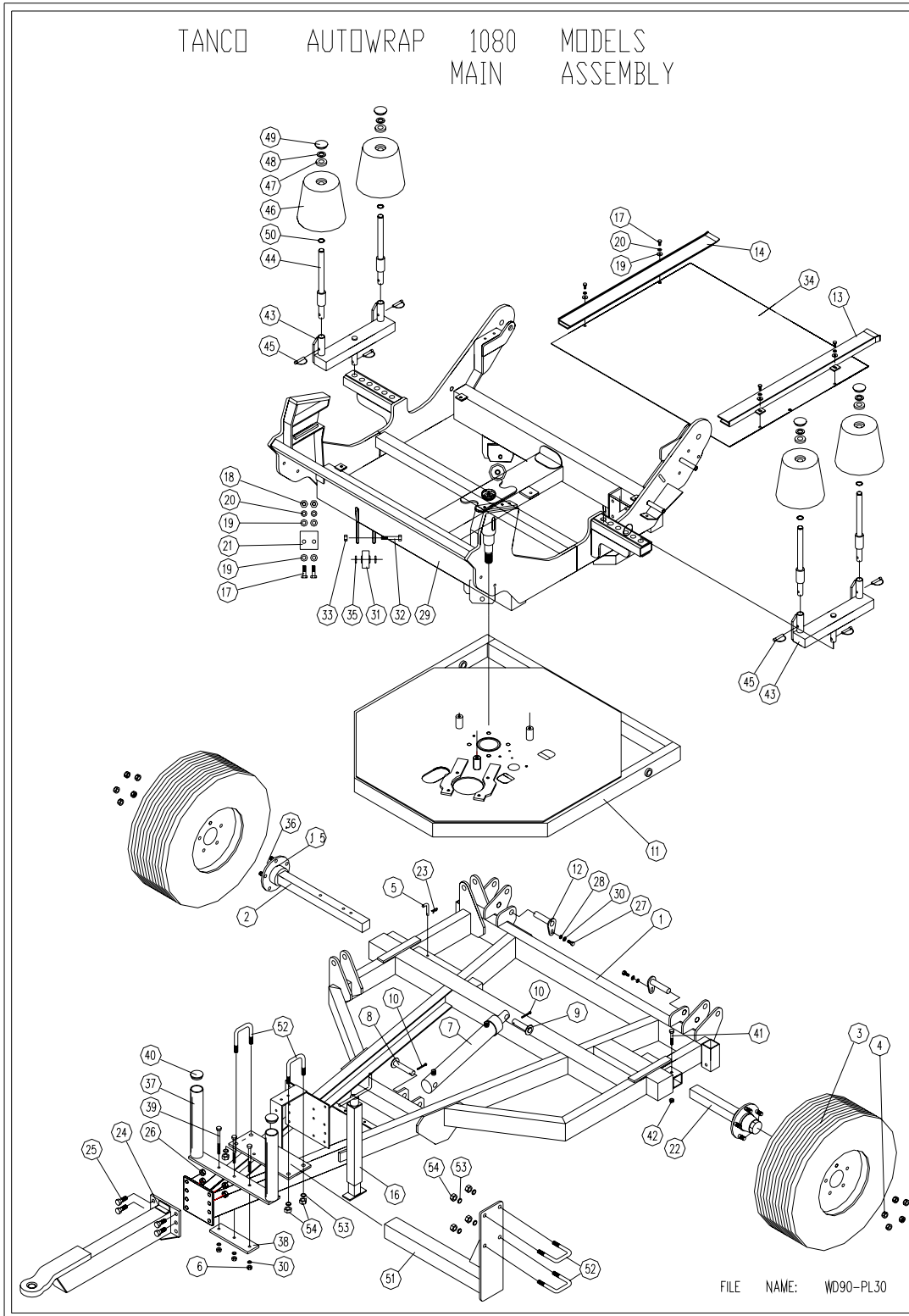



2.1.2 MAIN ASSEMBLY 1080A

ITEM No.	DESCRIPTION	QTY	PART No.
1.	Chassis Assembly	1	WD67-CHA
2.	Stub Axle (long)	1	Z04-0336
2A.	(for bearings and cap see 15,36and 22A below)		
3.	Wheels 31 x 15.5 x 15. 8 ply	2	Z04-04-1070
4.	Wheel Nuts	10	M22AWNA
5.	Bissel Pin	1	WD60-861
6.	M10 Hex Nut	3	Z18-10
7.	Hydraulic Ram	1	Z01-01-AR687
8.	Ram Bottom Pivot Pin	1	Z03-02-330
9.	Ram Top Pivot Pin	1	Z03-03-50
10.	2" x 1/4" Split Pin	2	Z03-21-29
11.	Tipping Frame Assembly	1	WD67-TF
12.	Tipping Frame Pivot Pin c/w Grease Nipple	2	Z03-01-905
13.	Belt Guide Assy.	1	WD610-BG1
14.	Belt Guide Assy.	1	WD610-BG2
15.	Inner Bearing	2	M22AB-209
16.	Screw Jack Assembly (welded on)	1	Z49-87
17.	M8 x 25 Hex Set	4	Z26-040S
18.	M8 Hex Nut	8	Z18-08
19.	8mm Mud Flap Washer	16	Z11-02-081
20.	8mm Spring Washer	8	Z12-02-08
21.	Scraper	2	WD60-771
22.	Stub Axle (short)	1	Z04-032
22A.	Cap for Axle Hub	2	M22AH-60A
23.	4mm "R" Clip	1	Z36-02
24.	Ring Hitch Assembly (long)	1	WD65-HIT
25.	M16 x 60 Hex Set	4	Z26-126S
26.	M16 Locknut	4	Z23-16
27.	M10 x 25 Hex Set	2	Z26-060S
28.	10mm Flat Washer	2	Z11-02-10
29.	Turntable Assembly	1	WD90-TA
30.	10mm Spring Washer	5	Z12-02-10
31.	Support Wheels 4"	4	Z06-466W
32.	Axle Assy. c/w Grease Nipple	4	Z03-22-AW/AX
33.	M20 Locknut	4	Z23-20
34.	Turntable Cover Plate	1	WD60-093
35.	Spacer	8	WD60-198
36.	Outer Bearing	2	M22AB-206



2.1.2 MAIN ASSEMBLY 1080A

ITEM No.	DESCRIPTION	QTY	PART No.
37.	Film Transport Bracket	1	WD60-FTB1
38.	Clamping Plate	1	WD60-933
39.	M10 x 140 Hex Bolt	3	Z26-0726B
40.	Plastic Cap	2	Z32-08
41.	M10 x 80 Hex Bolt	1	Z26-0691B
42.	M10 Locknut	1	Z23-10
43.	End Roller Mounting Bracket	2	WD90-RMB
44.	End Roller Shaft Assy.	4	WD610-RSA
45.	10mm Linch Pin	6	Z38-03
46.	Side Roller	4	Z06-AWR
47.	Bearing 63052RS	4	Z06-AWRB-93
48.	Thrust Washer	4	WD60-292
49.	Plastic Cap	4	Z06-AWRC
50.	Circlip	4	Z28-525
51.	Dispenser Mast Mounting Bracket	1	WD67-DMM
52.	80mm M16 "U" Bolt	4	Z35-32
53.	16mm Spring Washer	4	Z12-02-16
54.	M16 Nut	4	Z18-16

2.2.1 Constant Indexing Drive Assembly

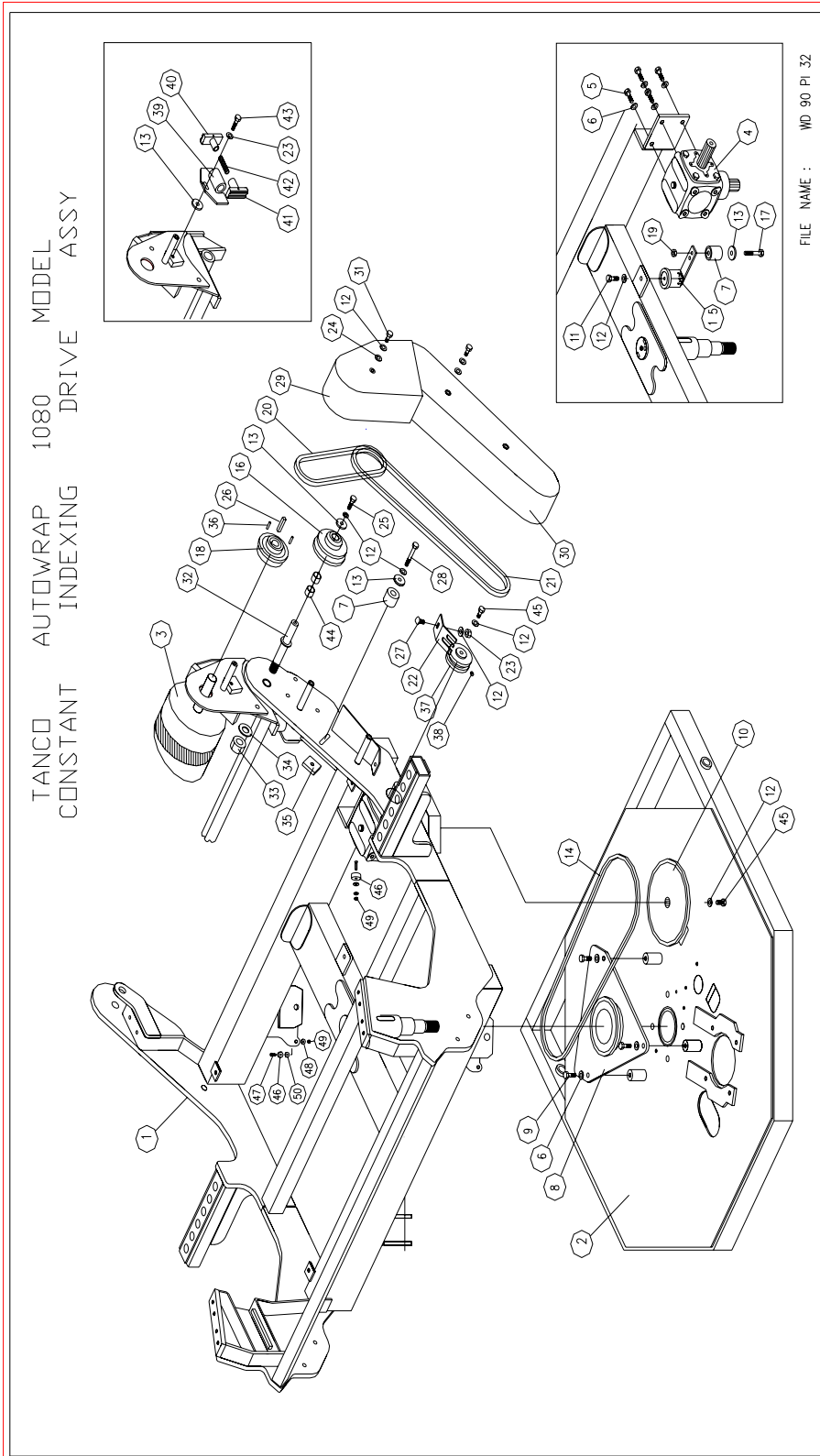



2.2.2 1080A Constant Indexing Drive Assembly

ITEM No.	DESCRIPTION	QTY	PART No.
1.	Turntable Assembly	1	WD90-TA
2.	Tipping Frame Assembly	1	WD67-TF
3.	Drive Roller Assembly	1	WD610-BRD1
4.	Gear Box	1	Z01-25-300
4A.	Gear Box Seal Kit	1	Z01-25-300S
5.	M12 x 30 Hex Set	4	Z26-082S
6.	12mm Spring Washer	7	Z12-02-12
7.	Chain Tensioner	2	WD60-CT
8.	Centre Sprocket Assy. 27 Tooth	1	WD64-CSA
9.	M12 x 25 Hex Set	3	Z26-081S
10.	46 Tooth Sprocket	1	Z06-D46-46S
11.	M10 x 25 Hex Set	1	Z25-0611S
12.	10mm Spring Washer	8	Z12-02-01
13.	Retaining Collar	4	WD623-071
14.	Chain ¾" Pitch x 101 Pitches	1	Z09-AW-56
15.	Rosta Tensioner	1	Z06-454
16.	Sprocket	1	Z06-D610-1620
17.	M10 x 65 Hex Bolt	1	Z26-0671B
18.	Sprocket	1	Z06-D610-20K
19.	M10 Locknut	1	Z23-10
20.	Chain ¾" Pitch x 50 Pitches	1	Z09-AW-52
21.	Chain ¾" Pitch x 75 Pitches	1	Z09-AW-75
22.	Chain Stripper	1	TD610-185
23.	M10 Hex Nut	2	Z18-10
24.	10mm Flat Washer	6	Z10-02-10
25.	M10 x 30 Hex Set	3	Z26-062S
26.	Key 12mm x 55mm Long	1	WD610-198
27.	M10 x 30 Cup Sq. Screw	1	Z13-112
28.	M10 x 80 Hex Bolt	1	Z26-00691B
29.	Chain Guard Small	1	WD90-CGS
30.	Chain Guard Large	1	WD90-044
31.	M10 x 25 Hex Set	1	Z26-0611S
32.	Sprocket/Bracket Pivot Shaft	1	WD610-71
33.	1" UNC Locknut	1	Z23-251
34.	1" H.D. Flat Washer	2	Z10-02-25
35.	Locking Plate	2	WD623-060
36.	Spiral Pin	2	Z03-23-062
37.	Sprocket	1	Z06-D65-1316S
38.	M6 Grub Screw	2	Z28-006
39.	Chain Tensioner Bracket	1	WD610-CTB1
40.	Chain Tensioner Block Assy. Inner	1	WD610-TBI1
41.	Chain Tensioner Block Assy. Outer	1	WD610-TBO1
42.	Spring 14.5 O.D. x 1.6mm Wire x 60 Long	1	Z07-48
43.	M10 x 40 Hex Set	1	Z26-064S
44.	Oilite Bush	2	Z06-106
45.	M10 x 30 Set (Grade 10.9)	2	Z26-062SB
46.	Magnet	2	D6043
47.	M6 x 35 Csk. Hd. Set	2	Z13-132
48.	6mm Dia. Flat Washer	2	Z11-02-06
49.	M6 Locknut	2	Z23-06

2.3 TABLE LOCKING ARRANGEMENT

ITEM No.	DESCRIPTION	QTY	PART No.
1.	Tipping Frame (underside view)	1	WD67-TF
2.	Turntable Centre Shaft	1	WD67-017
3.	Spindle Spacer	1	WD67-SS
4.	1 ¼ UNC Retaining Nut	1	WD64-054
5.	M8 x 6 Grub Screw	2	Z28-007

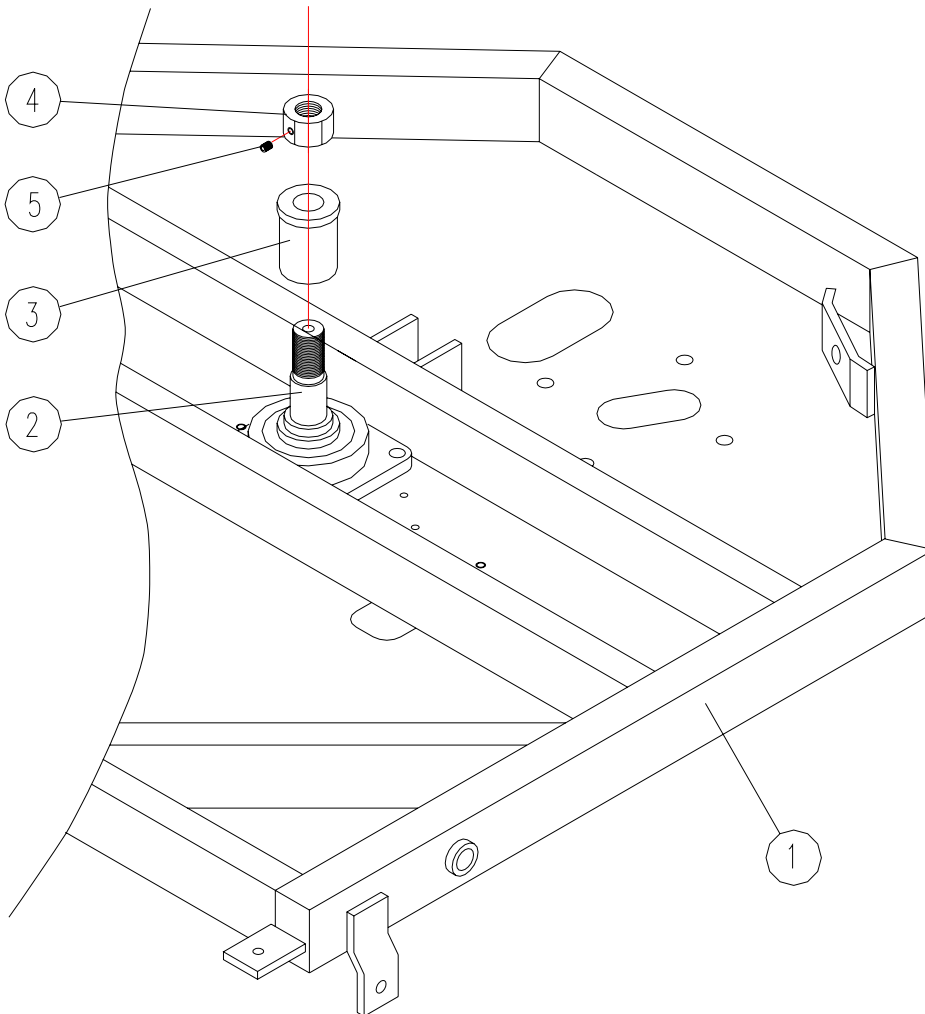

FILE NAME : WD 64 - PL41

2.4.1 Bale Belt Roller Mounting Brackets

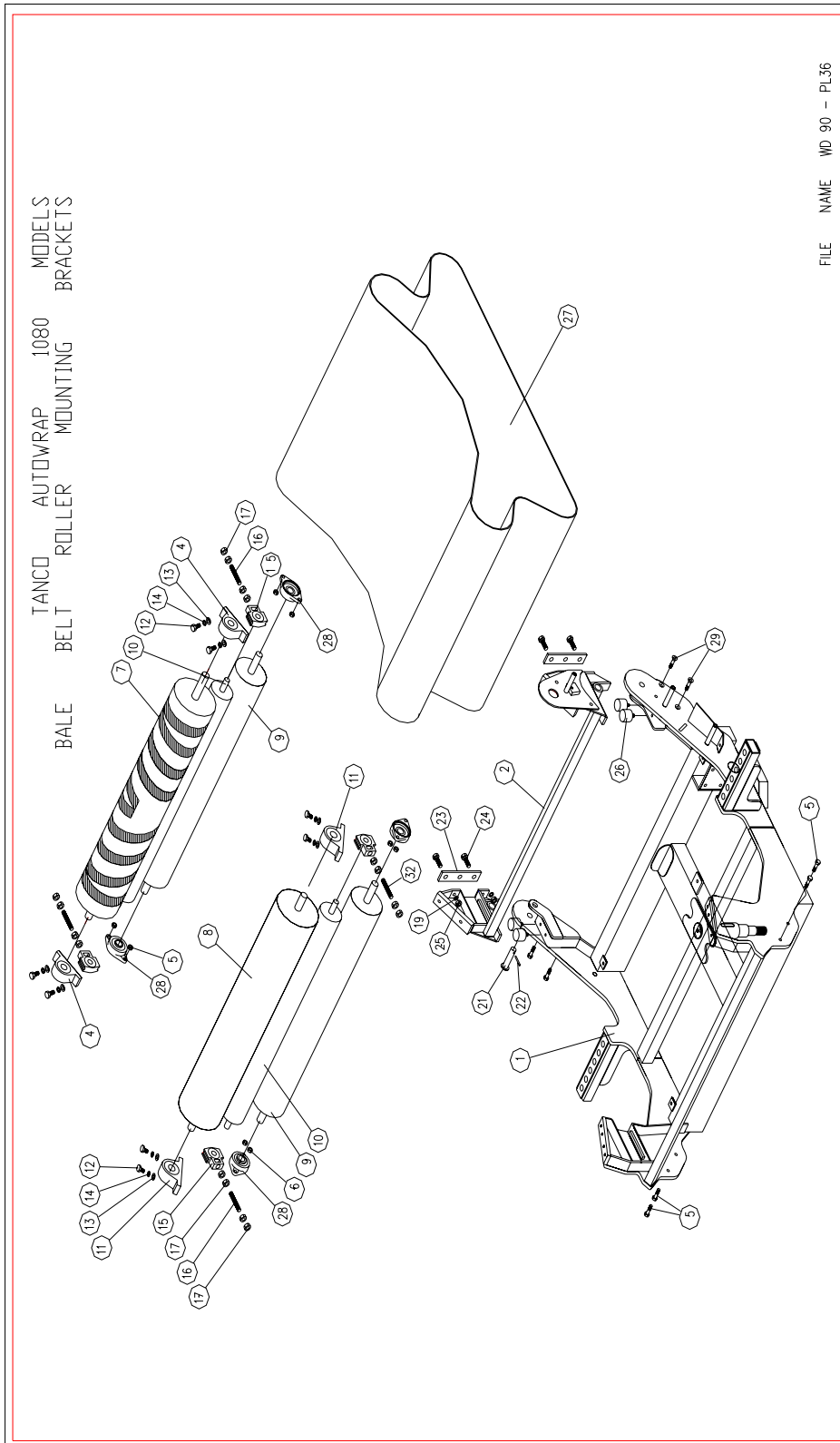



2.4.2

**TANCO AUTOWRAP 1080 MODEL
BALE BELT ROLLER MOUNTING BRACKETS
Parts list**

ITEM NO.	DESCRIPTION	QTY	PART NO.
1	TURNTABLE ASSY	1	WD90-TA
2	ROLLER MOUTING BRACKET (SWIVEL)	1	WD610-RMS1
3	M20THREADED BAR X 105 MM LONG	1	WD610-113
4	40MM DIA PILLOW BLOCK BEARING	2	Z06-48EC-40
5	M12 X 45MM SETS	6	Z26-085S
6	M12 LOCKNUTS	8	Z23-12
7	BIG ROLLER ASSY (DRIVE)	1	WD610-BRD1
8	BIG ROLLER ASSY (IDLER)	1	WD610-BRI
9	ROLLER ASSY (IDLER)	2	WD65-BRI
10	TRAKKING ROLLER ASSY (LONG)	2	WD610-TRL
11	1 ¼" PILLOW BLOCK BEARING	2	Z06-485
12	M14 HEX HD SET x 45 mm LONG	8	Z26103S
13	14 MM DIA FLAT WASHER	16	Z11-02-14
14	14MM DIA SPRING WASHER	16	Z12-02-14
15	SLIDING BEARING	4	Z06-47ST
16	M20 THREADED BAR x 135mm LONG	3	WD610-77
17	M20 HEX NUTS	16	Z18-20
18	12mm DIA SPRING WASHER	12	Z12-02-12
19	12mm DIA FLAT WASHER	8	Z11-02-10
21	SWIVEL BRACKET PIVOT PIN J-50	1	Z03-03-50
22	2" x ¼" SPLIT PIN	1	Z03-21-29
23	RETAINING PLATE	2	WD610-30
24	M12 HEX HD SETS x 40mm	4	Z26-084S
25	M12 HEX NUTS	6	Z18-12
26	BUFFER 50mm DIA x 42mm LONG	4	Z40-23
27	BALE BELT 1130mm WIDE x 4470mm LONG	1	Z05-02AWV193
28	1 ¼" FLANGE BEARING 2 HOLE	4	WD610-CSM
29	12 x 50 C/S TALLER SOREN	2	Z13-5-12x50

2.5.1

Turntable Chain Drive assembly

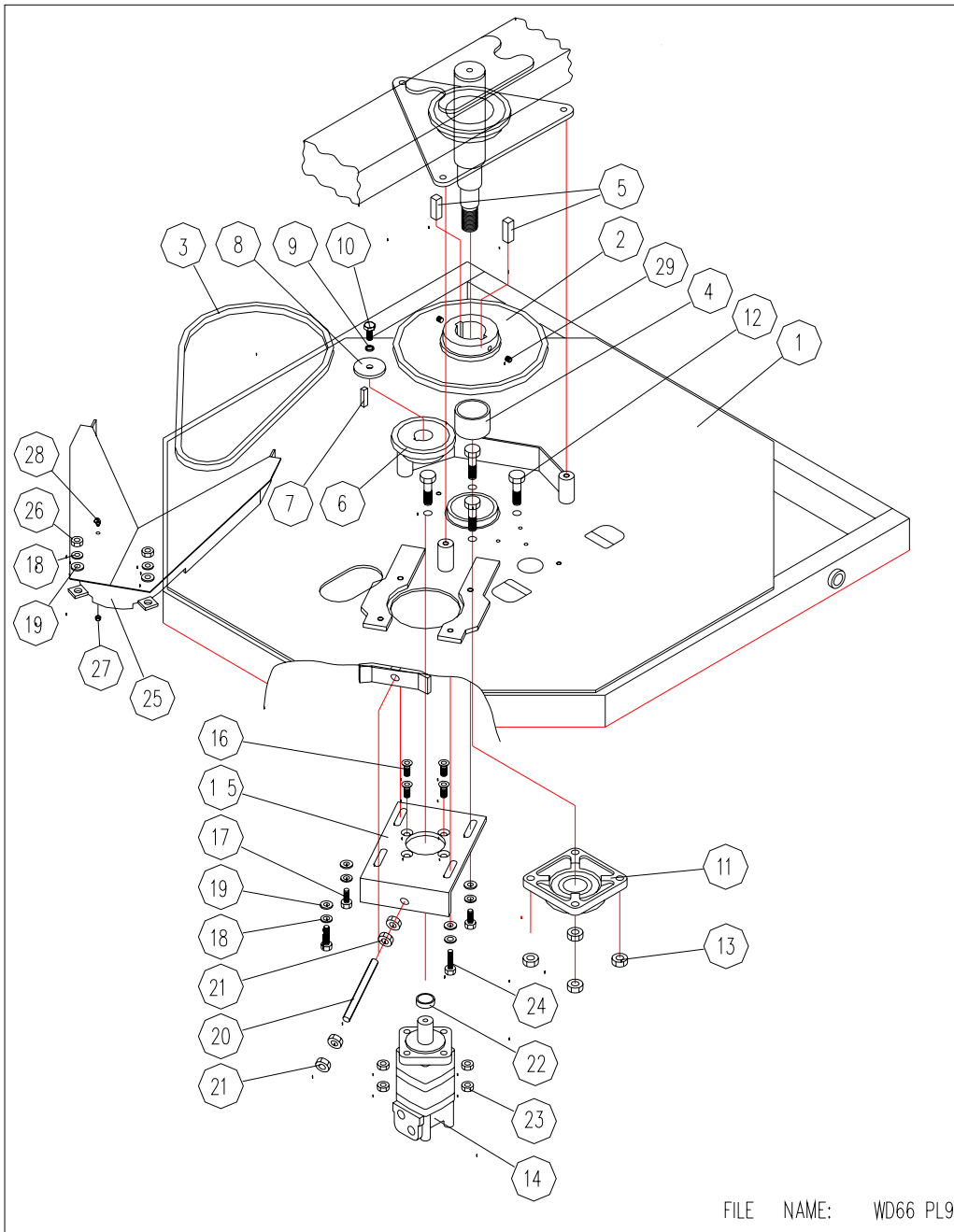

WD90PL32



2.5.2 TURNTABLE CHAIN DRIVE ASSEMBLY

ITEM No.	DESCRIPTION	QTY	PART No.
1.	Tipping Frame Assembly	1	WD67-TF
2.	38 Tooth x 1" Pitch Sprocket	1	Z06-D64-38
3.	Chain 1" Pitch x 54 Pitches	1	Z09-AW6
4.	Spindle Spacer	1	WD64-040
5.	Key, 5/8" Sq. x 50mm Long	2	WD64-052
6.	15 Tooth x 1" Pitch Sprocket	1	Z06-I60-046
7.	Key, 5/16" Sq. x 45mm Long	1	WD64-053
8.	Locking Collar	1	WD623-071
9.	10mm Spring Washer	1	Z12-02-10
10.	3/8" x 1" Long UNC Hex Set	1	Z27-023S
11.	2" Flange Bearing c/w Cam Lock Collar	1	Z06-49EC
12.	5/8" x 2" Long UNF Hex Set	1	Z31B-064
13.	5/8" UNF Locknut	4	Z20-10
14.	Hydraulic Motor	1	Z01-02-FR200
15.	Hydraulic Motor Mounting Plate	1	WD64-001
16.	M12 x 50mm Allen Hd. Csk. Set	4	Z13-5-12X50
17.	M12 x 30 Hex Set	2	Z26-082S
18.	12mm Spring Washer	6	Z12-02-12
19.	12mm Flat Washer	6	Z11-02-12
20.	M16 Threaded Bar x 165 Long	1	WD64-038
21.	M16 Hex Nut	4	Z18-16
22.	Spacer	1	Wi60-093
23.	M12 Locknut	4	Z23-12
24.	M12 x 50 Hex Set	2	Z26-086S
25.	Drive Chain Guard	1	WD66-DCG
26.	M12 Hex Nut	2	Z18-12
27.	M6 Hex Nut	1	Z18-06
28.	M6 90 Deg. Grease Nipple	1	Z39-65
29.	M12 Grub Screw	2	Z28-012



3.1 Lift Arm Assembly

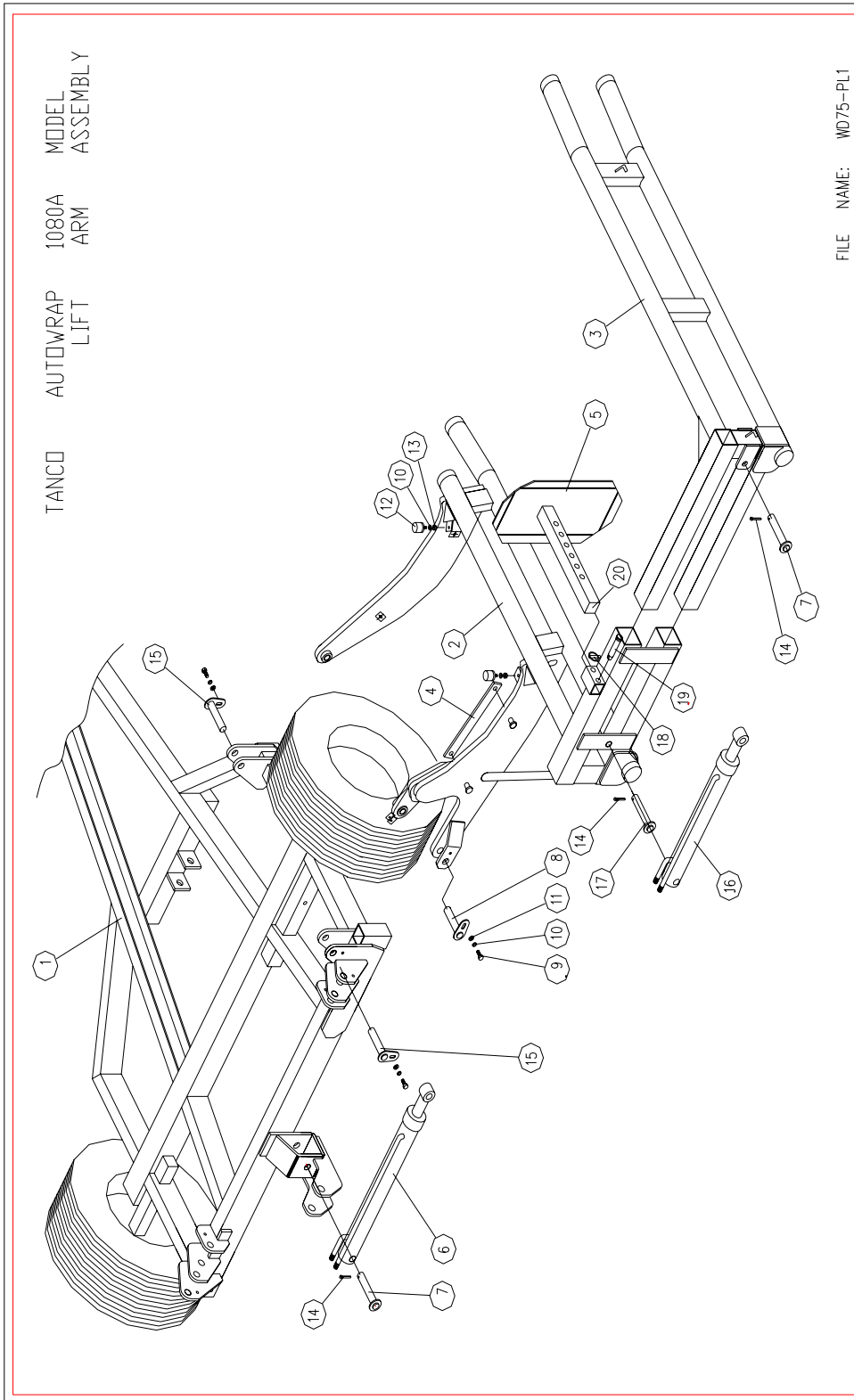



3.2 1080A LIFT ARM ASSEMBLY

ITEM No.	DESCRIPTION	QTY	PART No.
1.	Chassis Assembly	1	WD67-CHA
2.	Inner Arm Assembly	1	WD75-LA1
3.	Outer Arm Assembly	1	WD75-LAO
4.	Safety Arm Support	1	WD60-319
5.	Bale Stop Assembly	1	WD610-LAS1
6.	Hydraulic Ram (Lift Arm)	1	Z01-01-AW1070
7.	Ram Boss Pivot Pin	1	Z03-02-330
8.	Ram Top Pivot Pin	1	Z03-D66-90
9.	M10 x 20 Hex Set	3	Z26-060S
10.	10mm Spring Washer	5	Z12-02-10
11.	10mm Flat Washer	3	Z11-02-10
12.	Buffer 50mm Dia. X 40 Long	2	Z40-20
13.	M10 Hex Nut	2	Z18-10
14.	2" x 1/4" Split Pins	3	Z03-21-29
15.	Lift Arm Pivot Pin c/w Grease Nipple	2	Z03-01-905
16.	Hydraulic Ram (Outer Frame)	1	Z01-01-140S
16A	Seals for above Ram	1	Z01-R01
17.	Ram Top/Bottom Pivot Pin	2	Z03-D66-145
18.	Bale Stop Retaining Pin	1	Z03-04-73
19.	7/16" Dia. Linch Pin	1	Z03-22-06
20.	Plastic Cap	1	Z32-10

4.1 Cut and Start Assembly

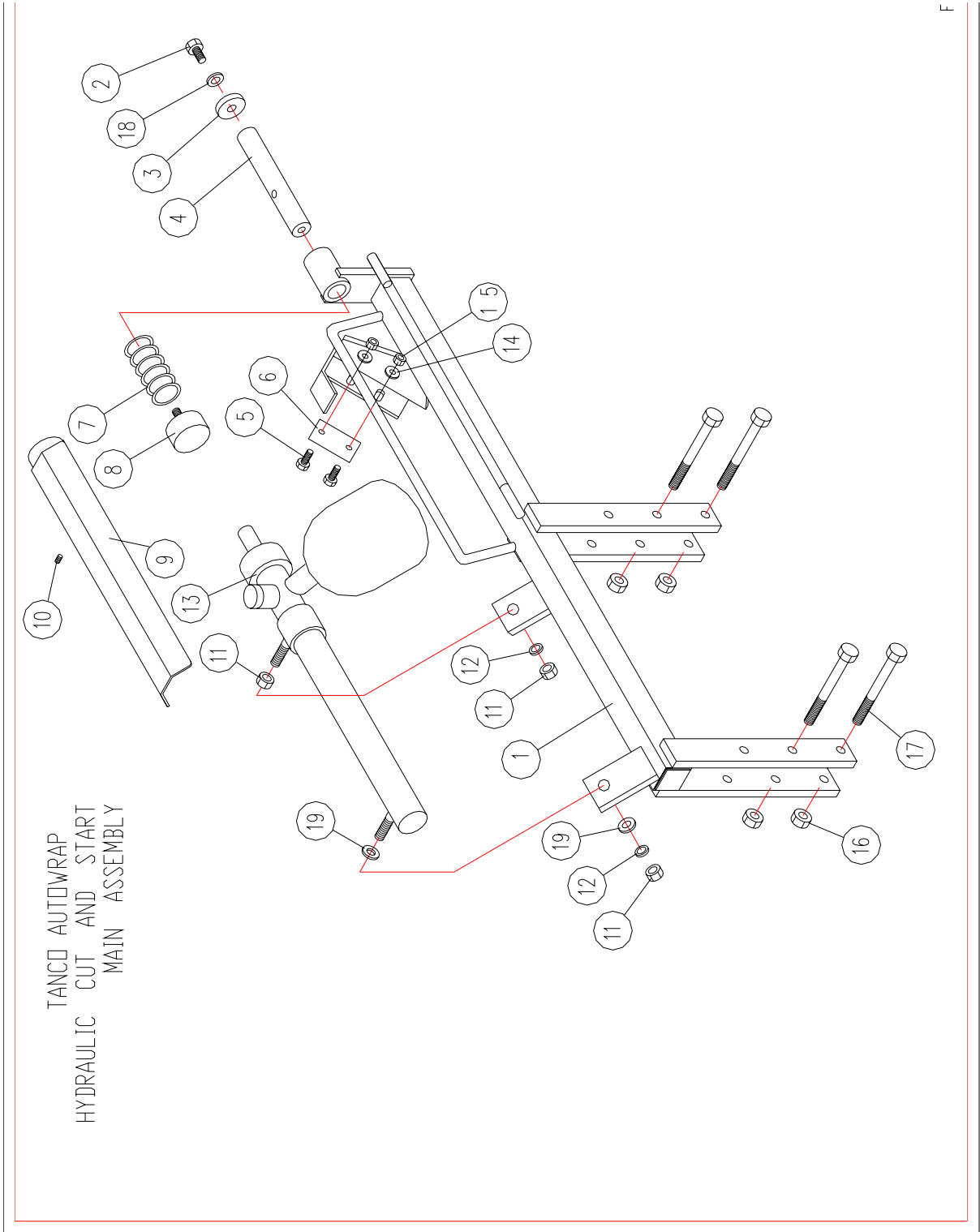

F



4.2 HYDRAULIC CUT AND START ASSEMBLY

ITEM No.	DESCRIPTION	QTY	PART No.
1.	Hydraulic Cut and Start Main Frame	1	WD605H-MF1
2.	M10 x 25 Hex Set	1	Z26-0611S
3.	Locking Collar	1	WD623-071
4.	Gripper Rod	1	WD605H-13
5.	M8 x 25 Hex Set	2	Z26-040S
6.	Blade	1	WD605-104
7.	Spring	1	Z07-49
8.	Gripper Pad (rubber)	1	Z40-28
9.	Gripper Pad	1	WD605H-15
10.	M8 x 10 Grub Screw	1	Z28-008
11.	M14 Hex Nut	3	Z18-14
12.	14mm Spring Washer	2	Z12-02-14
13.	Hydraulic Ram c/w Accumulator (Cut and Start)	1	Z01-01-AWH9
13A	Hydraulic Ram for above	1	Z01-01-AWH9C
13B	Accumulator for above Ram	1	Z01-01-AWDA
13C	Charging Check Valve for above Ram	1	Z01-01-AWV
14.	8mm Mud Flap Washer	2	Z11-02-081
15.	M8 Locknut	2	Z23-08
16.	M10 Locknut	4	Z23-10
17.	M10 x 75 Hex Bolt	4	Z26-069B
18.	10mm Spring Washer	1	Z12-02-10
19.	14mm Flat Washer	2	Z11-02-14

5.1.1 HYDRAULIC BALE RAMP

ITEM No.	DESCRIPTION	QTY	PART No.
1.	Hydraulic Bale Ramp	1	WD65-HBRF
2	Ramp Main Pivot Pin c/w Grease Nipple	2	Z03-01-905
3.	M10 x 20 Hex Set	2	Z26-060S
4.	10mm Flat Washer	2	Z11-02-10
5.	10mm Spring Washer	7	Z12-02-10
6.	Bale Mat	1	Z05-02-BRM
7.	M10 x 30 Cup Hd. Sq. Set	5	Z13-112
8	M10 Hex Nut	5	Z18-10
9.	Hydraulic Ram c/w Accumulator	1	Z01-01-AWD
9A	Hydraulic Ram only for above assembly	1	Z01-01-AWDC
9B.	Accumulator for above assembly	1	Z01-01-AWDA
9C.	Charging Valve for above assembly	1	Z01-01-AWV
9E	Hose for above assembly	1	Z01-01-AWDH
10.	Sparex Pin	1	Z03-04-74
11.	Sparex Pin	1	Z03-04-73
12.	7/16" Linch Pin	2	Z03-22-06
13.	M28 x 1.5 Pitch Hex Nut	1	Z001-243
14	10mm Mud Flap Washer	5	Z11-02-101

10.1.2

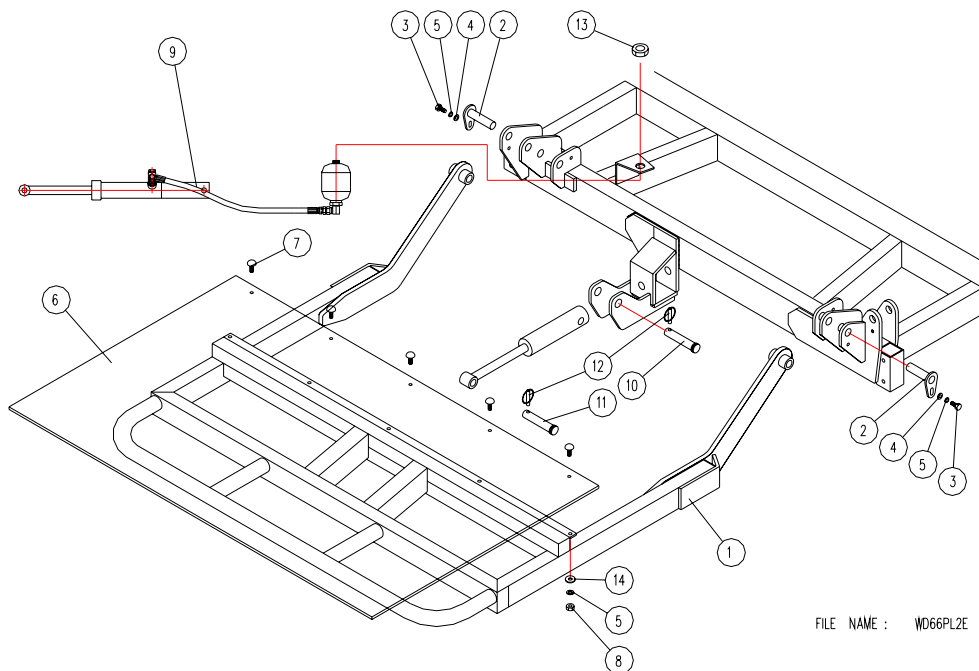

FILE NAME : WD66PL2E



6.1 LIGHTING KIT

ITEM No.	DESCRIPTION	QTY	PART No.
	Lighting Kit Complete	1	Z05-30
1.	Light Mounting Bracket R.H.S.	1	WD60-LMB
2.	Light Mounting Bracket L.H.S.	1	WD60-899
3.	Light Cluster	2	Z01-30LP
4.	M8 x 25 Hex Set	4	Z26-040S
5.	M8 Locknut	4	Z23-08
6.	Reflector	2	Z04-621
7.	M12 x 100 Hex Bolt	2	Z26-092B
8.	M12 x 90 Hex Bolt	2	Z26-091B
9.	M12 Locknut	4	Z23-12

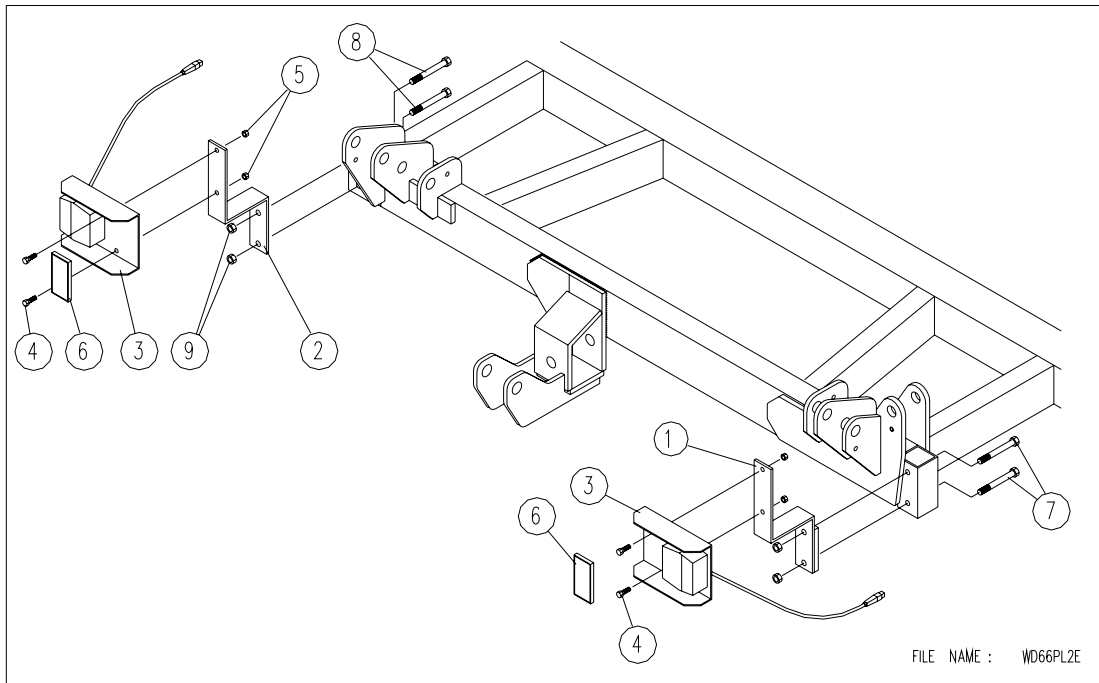



7.1.1 Dispenser Mast Assembly

0/280/1080 Dispenser Assembly

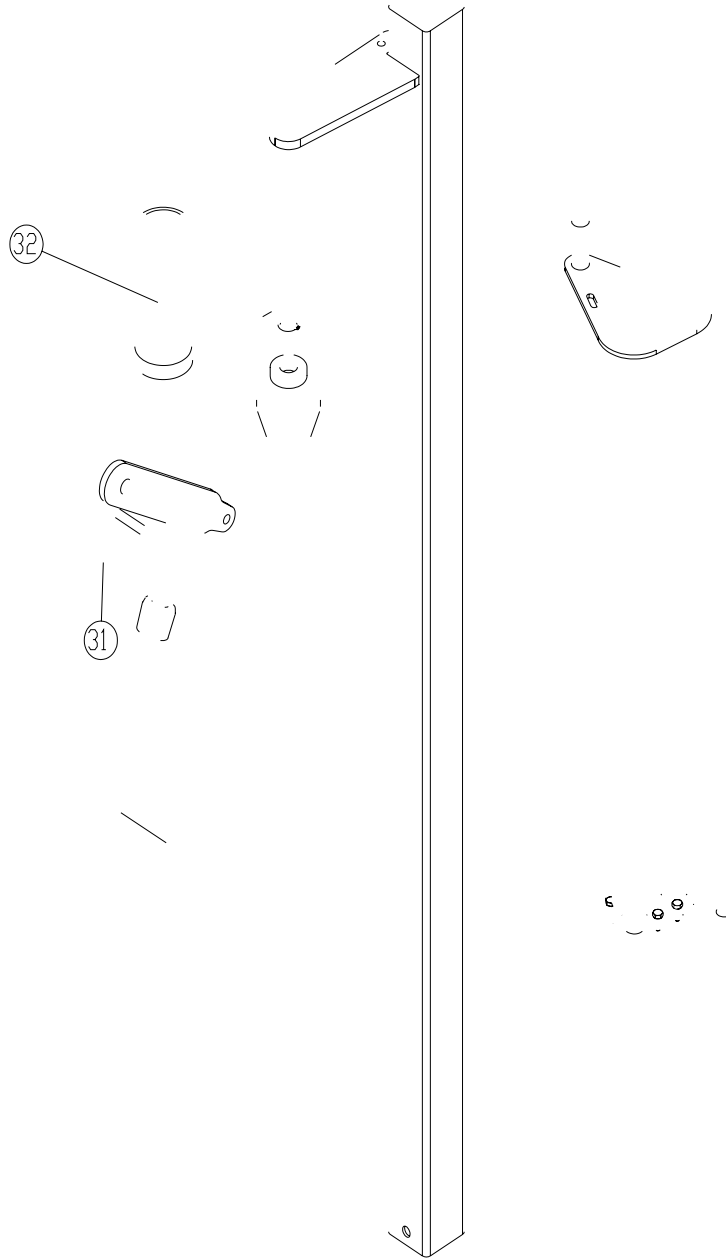



2 Dispenser parts list

ITEM	PART NO.	QTY	DESCRIPTION
	1205000	1	TW Dispenser complete
1	WD90-DM	1	Dispenser mast frame
2	1305010	1	Bottom latch
3	Z23-08	1	M.8 Locknut
4	1305015	2	Bearing
5	1305016	1	Bottom cone
6	1305017	3	Cir-clip 25 mm
7	1305018	1	Plastic cap 1 1/4"
8	1305019	1	Upper cone
9	1305020	2	25mm dia. flat washer
10	1305021	1	Spring
11	1305022	1	Top shaft
12	Z26-067B	1	M10 x 60 Hex bolt
13	WD13-006	1	Top latch
14	1305027	1	Spring
15	Z11-02-11	2	M 10 flat washer
16	Z23-10	1	M.10 Locknut
17	1305030	1	Pivot pin
18	1305033	1	Split pin
19	1305034	1	Torsional spring
20	1205100	1	TW Insert
21	Z003-1200	1	Latch release wire kit
22	WD617-FPDA	1	Film Pull down arm assembly
23	WD60-866	1	Plastic Roller
24	WD60-859	1	Retaining washer
25	Z01-23-29	1	1/4" x 2" Split pin
26	Z01-01-AW25	1	Hydraulic Ram (pull down)
27	Z23-16	1	M16 Locknut
28	Z26-086S	1	M12 x 50 Bolt
29	Z23-12	1	M12 Locknut
30	Z23-20	1	M 20 Locknut
31	Z32-14	1	1" G.B plastic cap
32*	WD60-FA	1	500 mm Film adaptor

* indicates optional equipment

7.2.1. TW Dispenser insert

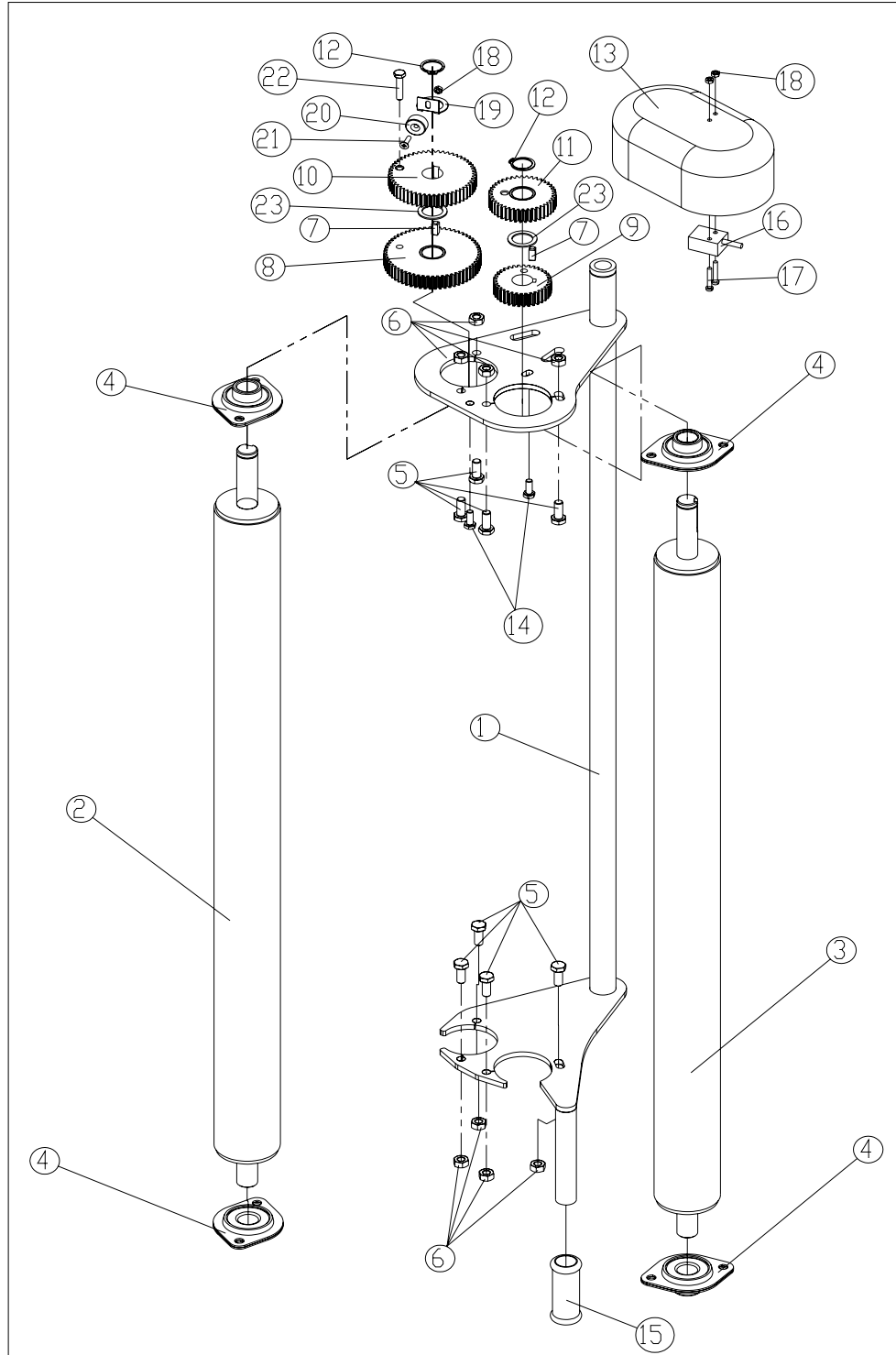



7.2.2 TW Dispenser insert Parts list

ITEM	PART NO.	QUANTITY	DESCRIPTION	Dimension
	1205100	1	TW insert complete	
1	1205101	1	TW Insert Frame	
2	1305120	1	Inner Roller	
3	1305121	1	Outer Roller	
4	1305122	4	Bearing	RHP SLF20A
5	Z26-039S	8	M8 * 20 Bolt	
6	Z23-08	8	M8 Locknut	
7	1305123	2	6 mm square key steel	15 mm long
8	1305101	1	60 t gear	16 mm
9	1305102	1	35 t gear	16 mm
10	1305105	1	54 t gear	16 mm
11	1305106	1	41 t gear	16 mm
10*	1305103		58 t Gear	16 mm
11*	1305104		37 t Gear	16 mm
12	1305124	2	20 mm external cir-clip	
13a	1305125	1	Dispenser gearbox cover	
13b**	1305126	1	Dispenser gearbox cover	(c/w holes)
14	Z26-018S	2	M6 * 16 mm bolt	
15	Z32-16	1	Plastic hand grip	
16**	D606C-SS1	1	Film break Sensor	
17**	Z13-4-04x25	2	M4 x 25 Allen head	
18**	Z23-04	3	M4 lock nut	
19**	WD404-052	1	Magnet mounting bracket	
20**	D606C-SM1	1	Magnet	
21**	Z13-125	1	M4 x 20 countersunk screw	
22	Z26-0225	1	M6 x 30 bolt	
23	1305115	2	Copper Washer between gears	
*	Optional 55% Stretch Gears			
**	Optional Film Break Sensor			

N.B. The 1080 model is fitted with 55% stretch gears in position 5 & 6

8.1. SENSOR AND MAGNET MOUNTING BRACKETS

ITEM No.	DESCRIPTION	QTY	PART No.
1.	Magnet Mounting Bracket	1	WD605-165
2.	Magnet	1	ZD605-200
3.	M6 x 30 Hex Set	1	Z26-022S
4.	6mm Flat Washer	2	Z12-02-06
5.	M6 Locknut	2	Z23-06
6.	M8 x 25 Hex Set	2	Z26-40S
7.	M8 Locknut	1	Z23-08
8.	8mm Spring Washer	2	Z12-02-08
9.	M8 Hex Nut	2	Z18-08
10.	M8 x 100 Hex Set	1	Z26-057S
11.	Sensor Mounting Bracket	1	WD608-58
12.	Sensor Mounting Flat	1	WD605-164

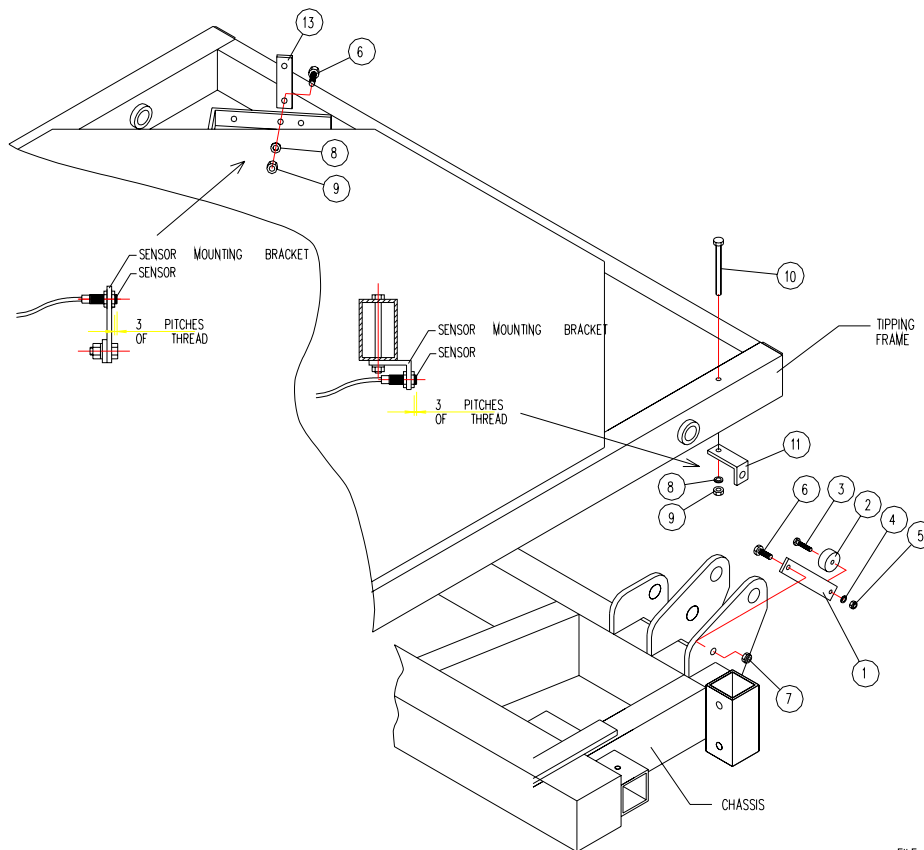

FILE NAME W080 - PL29

8.2 1080A Controller



ITEM	PART NO.	QUANTITY	DESCRIPTION
1	1209002	1	TW Control Unit
2	1209001		TW Faceplate RDS
3	1309009	1	2 pin connector Female + 2 spade pins
4	1309008	1	24 pin socket
5	1309009	1	Controller mounting bracket EH
6	1309012	1	Controller suction cup
7	1309007		Battery Cable (3m)
8	1309010		2 pin connector male + 2 female pins
9	1409001	1	Hand held Controller



Tanco Autowrap 580
Spare parts list

8.3 1080A JUNCTION BOX

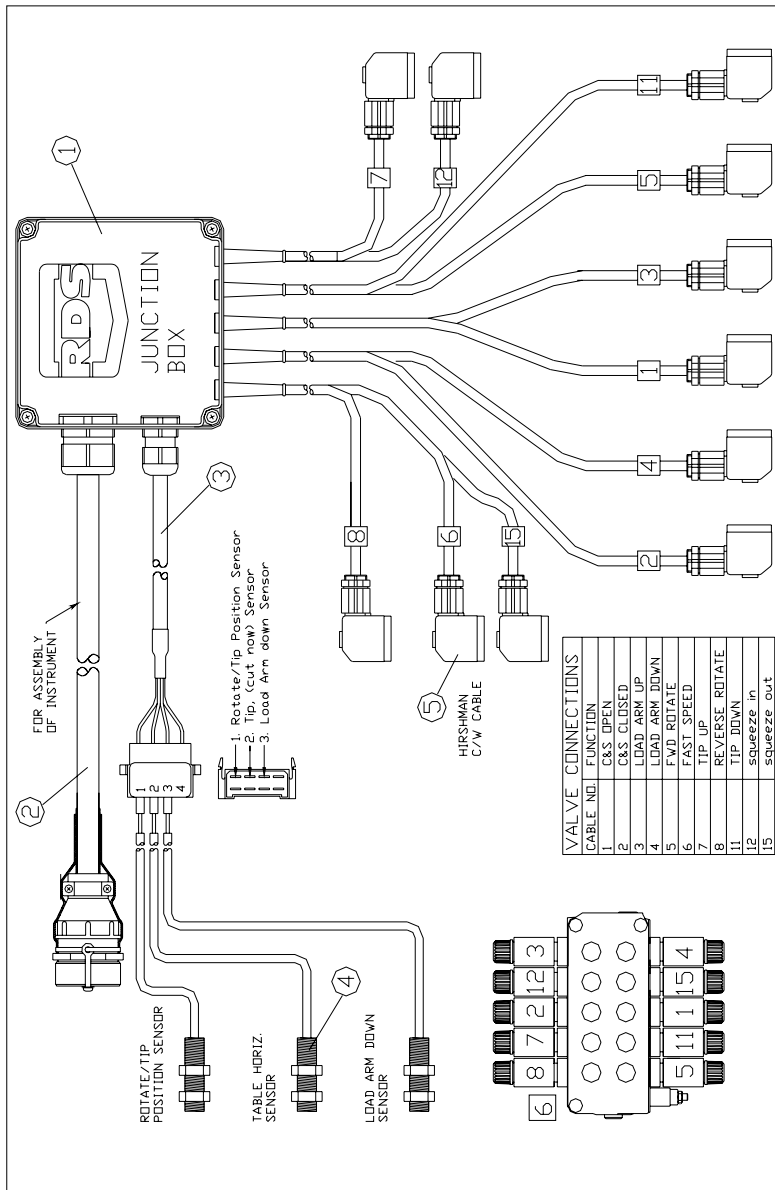

ITEM NO.	QTY.	PART NO.	DESCRIPTION
1	1	1009001	Junction Box Complete
2	1	1309003	Communication Cable
3	1	1009003	Sensor Cable
4	3	1009002	Sensor (3m)
5	11	1309005	Hirschmann, c/w Cable & gland